



History

HMS Starling was built by Fairfield Shipbuilders and Engineering Ltd, Govan and launched on 14th October 1942. She was completed to a design based on the Black Swan class of Escort Sloop but modified with better equipment and a slightly wider beam. She also had the new addition of stabilisers, which made her a good AA gun platform, which was ideal for her role as Anti Aircraft and Anti Submarine Escort ship.

Starling was completed in April 1943 and became the Leader of the 2nd Escort Group under the command of Captain F.J. Walker. Captain Johnie Walker was probably the most proficient Anti Submarine tactician of the war, and under his command Starling had a distinguished wartime record, being involved in, or responsible for, the sinking of at least sixteen U-Boats.

Six of the U-Boats were sunk in the space of one month between 31st Jan 1944 and 19th Feb 1944. This included the capturing of the crew of the U264, commanded by Hartwig Looks. This U Boat was the first to use the new Schnorkel device.

Sadly Captain Walker died of a stroke on 9th July 1944 at the age of 48, but his achievements will always be remembered.

HMS Starling survived the war and in 1948 had all of her armament removed. She became a Navigation Training Support ship with the Dartmouth Training Squadron. Large deck houses were built aft, in place of her gun housings and a lattice main mast fitted to take the additional radar and wireless antennas.

She continued in this role until 1959 when reduced to the Reserve Squadron, then finally she was sold off and broken up in 1965.

Specifications

Length Overall 299 ft 6 ins. Beam 37 ft 6 ins. Draught 8 ft 9 ins. (11 ft Max) Speed 18.5 knots.
Complement 192 Officers and Men.

Armament

Six 4" Guns in 3 Twin HA/LA Mountings. 8 to 12 20mm Oerlikons in either single or twin mountings.
2 Twin 40mm Hazemeyer mountings fitted in place of mid 20mm mountings.
Two stern mounted DC rails and 4 DC throwers.

RESIN & WHITE METAL PARTS IDENTIFICATION

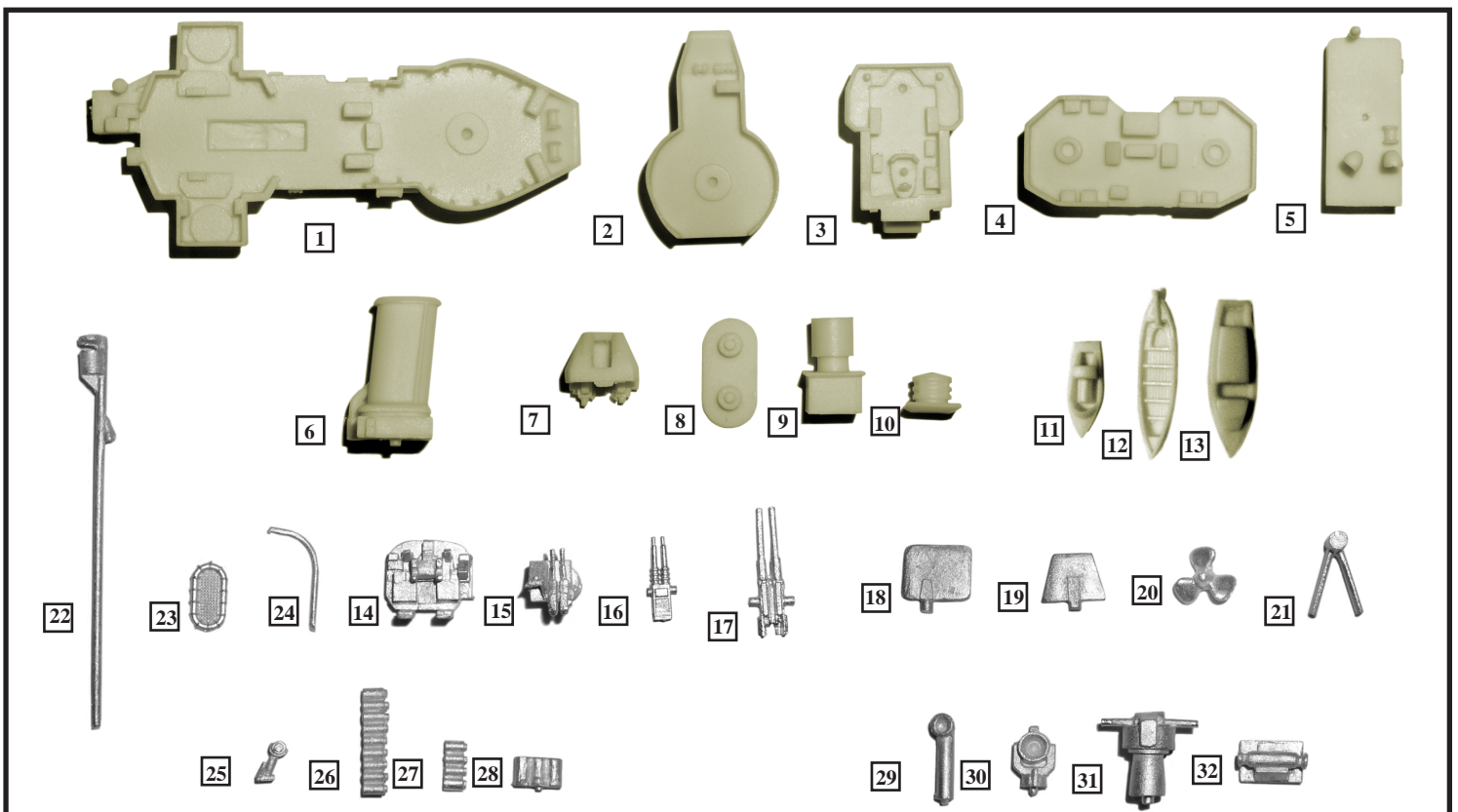

- | | | | |
|-----------------------------|---------------------------------|-----------------------------|------------------------------|
| 1. Forward Superstructure | 9. Early Radar Lantern | 17. Twin 4" Gun Barrels x 3 | 25. Depth Charge Thrower x 4 |
| 2. Aft Superstructure | 10. Late Radar Lantern | 18. Rudder | 26. Depth Charge Rail x 2 |
| 3. Bridge | 11. 14' Fast Motor Boat | 19. Stabiliser Fin x 2 | 27. Depth Charge Stack x 11 |
| 4. Amidships AA Platform | 12. 27' Whaler | 20. Propeller x 2 | 28. Smoke Generators x 2 |
| 5. Amidships Superstructure | 13. 25' Admiralty Motor Cutter | 21. Propeller 'A' Frame x 2 | 29. Large Ventilators x 2 |
| 6. Funnel | 14. 40mm Hazemeyer Mounting x 2 | 22. Fore Mast Pole | 30. Searchlight |
| 7. 4" HA/LA Gun Turret x 3 | 15. Twin 20mm Power Mount x 4 | 23. Carley Raft x 4 | 31. HACs Mk3 Director |
| 8. Aft AA Platform | 16. Twin 40mm Gun Barrels x 2 | 24. Boat Davits x 4 | 32. Anchor Windlass |

When assembling a Resin / Photoetched metal kit, certain precautions must first be taken.

1. Resin dust can be harmful if inhaled. It is recommended that you wear a suitable dust mask when drilling or sanding resin parts.
2. Cyano adhesives (super glues) are generally used to assemble this type of kit. Care must be taken when using this type of adhesive as it will bond in seconds. Follow the advice on the container.
3. Wash resin parts in a solution of warm soapy water before assembly. This will remove any residual mold release agents and ensure a good key for painting.
4. Soak photoetch parts in a suitable solvent, such as white spirit, to degrease the surfaces prior to painting.

List of Photo Etched Metal Parts

ATLANTIC MODELS © 2018

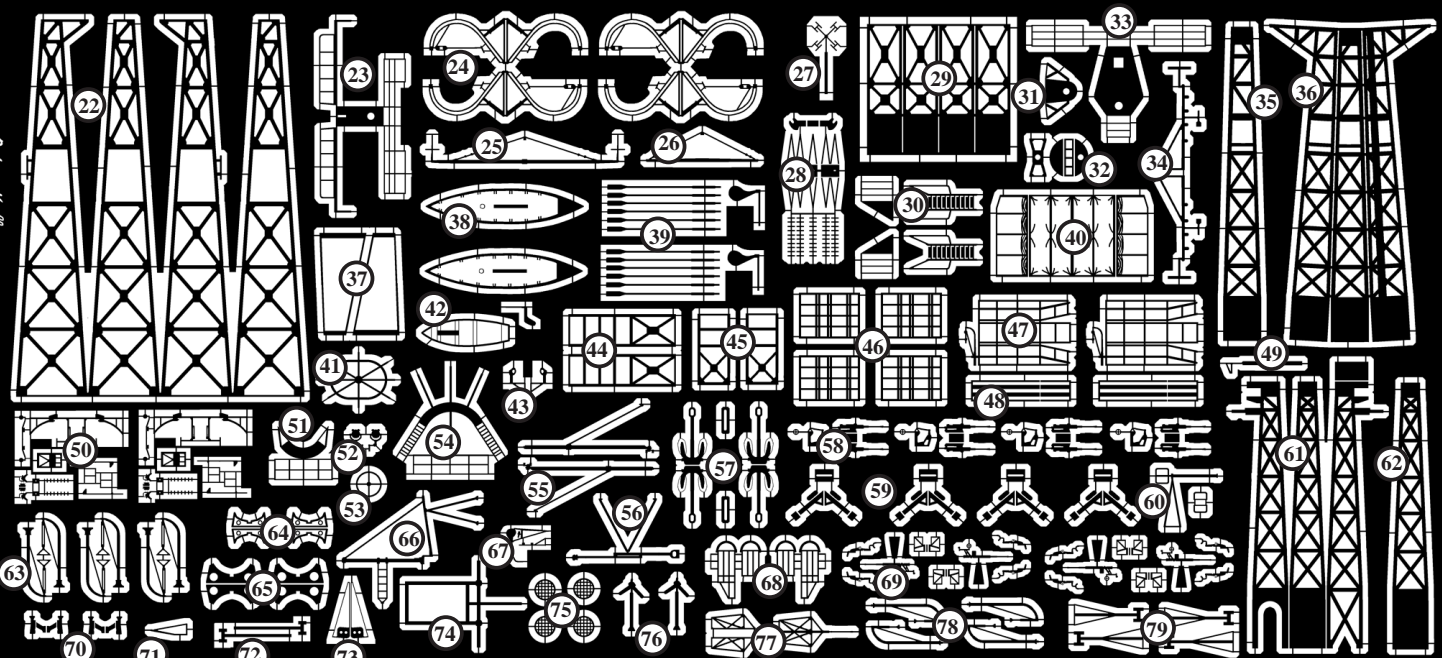
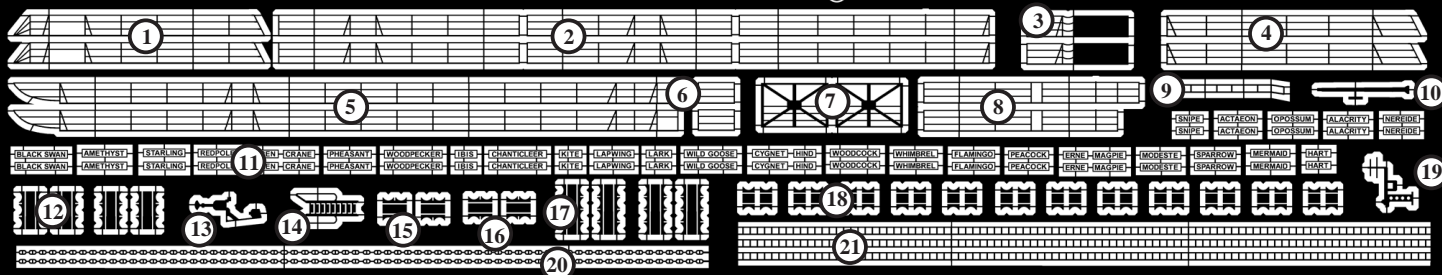

Black Swan Class Frigates 1/350 Scale

- | | | | |
|--|---------------------------------|------------------------------------|---------------------------------------|
| 1. Railings (Amethyst Bow) | 21. Vertical Ladder Stock | 41. Funnel Cap Grill | 61. Lattice Main Mast (Starling Late) |
| 2. Railings (Focle Deck) | 22. Lattice Mast (Tall) | 42. 14' Dinghy Thwarts and Rudder | 62. Lattice Main Mast Front |
| 3. Railings (B Gun Deck) | 23. Mast Top Platform and Yards | 43. Funnel Sirens | 63. Depth Charge Handling Davits |
| 4. Railings (Bow) | 24. Boat Davits | 44. Forward Carley Raft Racks | 64. 16' Motor Boat Cradles |
| 5. Railings (Quaterdeck) | 25. Tripod Foremast Lower Yard | 45. Aft Carley Raft Racks | 65. 25' Admiralty Cutter Cradles |
| 6. Railings (Hull Step Early) | 26. Tripod Foremast Upper Yard | 46. Vertical Depth Charge Racks | 66. Stern Boat Boom |
| 7. Forward AA Deck Supports | 27. 291 Radar Antenna | 47. Depth Charge Stern Rails | 67. 25' Admiralty Cutter Fittings |
| 8. Railings (Searchlight Platform) | 28. 285 FC Radar Yagi Antenna | 48. Depth Charge Stern Rail Tracks | 68. Rocket Flare Launcher Frames |
| 9. Bridge Windsreen | 29. Radar Lantern Main Mast | 49. Lattice Main Mast Top Pole | 69. Single 20mm Oerlikons |
| 10. Lattice Mast Top Pole (Early) | 30. Hull Step Inclined Ladders | 50. 40mm Hazemeyer Fittings | 70. Binocular Sights |
| 11. Ships Name Plates | 31. Lattice Mast Lower Platform | 51. Funnel Siren Platform | 71. Radar Lantern Mast Gaff |
| 12. Depth Charge Stowage Rack | 32. 293 Radar Antenna Assembly | 52. Signal Lamps | 72. Stove Pipes |
| 13. Tripod Mast Light Cluster | 33. Lattice Mast Top Platform | 53. Searchlight Lens Cross | 73. Bow Plate |
| 14. Inclined Ladder | 34. Lattice Mast Yardarms | 54. HACs Director Catwalk | 74. Wire Antenna Spreader Mast |
| 15. Depth Charge Stowage Rack (Twin) | 35. Lattice Mast Front | 55. Boat Booms | 75. Cowl Vent Grills |
| 16. Depth Charge Stowage Rack (Triple) | 36. Lattice Mast (Short) | 56. Jack Staff | 76. Bridge Semaphores |
| 17. Depth Charge Stowage Rack (Large) | 37. Tripod Foremast Spacers | 57. Anchors | 77. HF/DF Antenna Assembly |
| 18. Depth Charge Stowage Rack (Single) | 38. 27' Whaler Thwarts | 58. Twin 20mm Gun Fittings | 78. Ammunition Loading Davits |
| 19. Fore Mast ESM Antenna | 39. Whaler Oars and Rudder | 59. Depth Charge Throwers (Alt) | 79. Stove Pipes (Braced) |
| 20. Anchor Chain | 40. Bridge Canopy | 60. Bridge Front DF Antenna | |

General Instructions for working with Photo Etched Metal

1. Do not remove the etched parts from the fret until you are ready to use them.
2. Before assembly, soak the etched parts in a suitable solvent, such as white spirit, to de-grease the surfaces for painting.
3. Cyanoacrylate adhesive (Super glue) or contact adhesive such as Elmers white glue may be used. These can be applied with a pin or piece of stretched sprue.
4. When removing parts from the fret, place the fret on a hard surface, such as a smooth ceramic tile, in order to prevent parts bending whilst cutting through the holding tabs. It is suggested that a #11 type of modelling knife blade is used for this purpose.
5. When shaping or bending a part, a straight edged blade such as a chisel blade #17 or # 18 will give a good sharp corner, or alternatively a small pair of smooth jawed pliers may be used.
6. If a part is bent incorrectly, lay it on a hard flat surface and roll it flat with a cylindrical object such as a modelling knife handle.
7. It is suggested that rails are pre-measured, where practical, using a pair of compass dividers and then tacked to the deck edge every third or fourth stanchion with a small drop of glue. When a section is complete, run a thin line of glue along the inside edge to attach it firmly to the deck.

Main Component Location

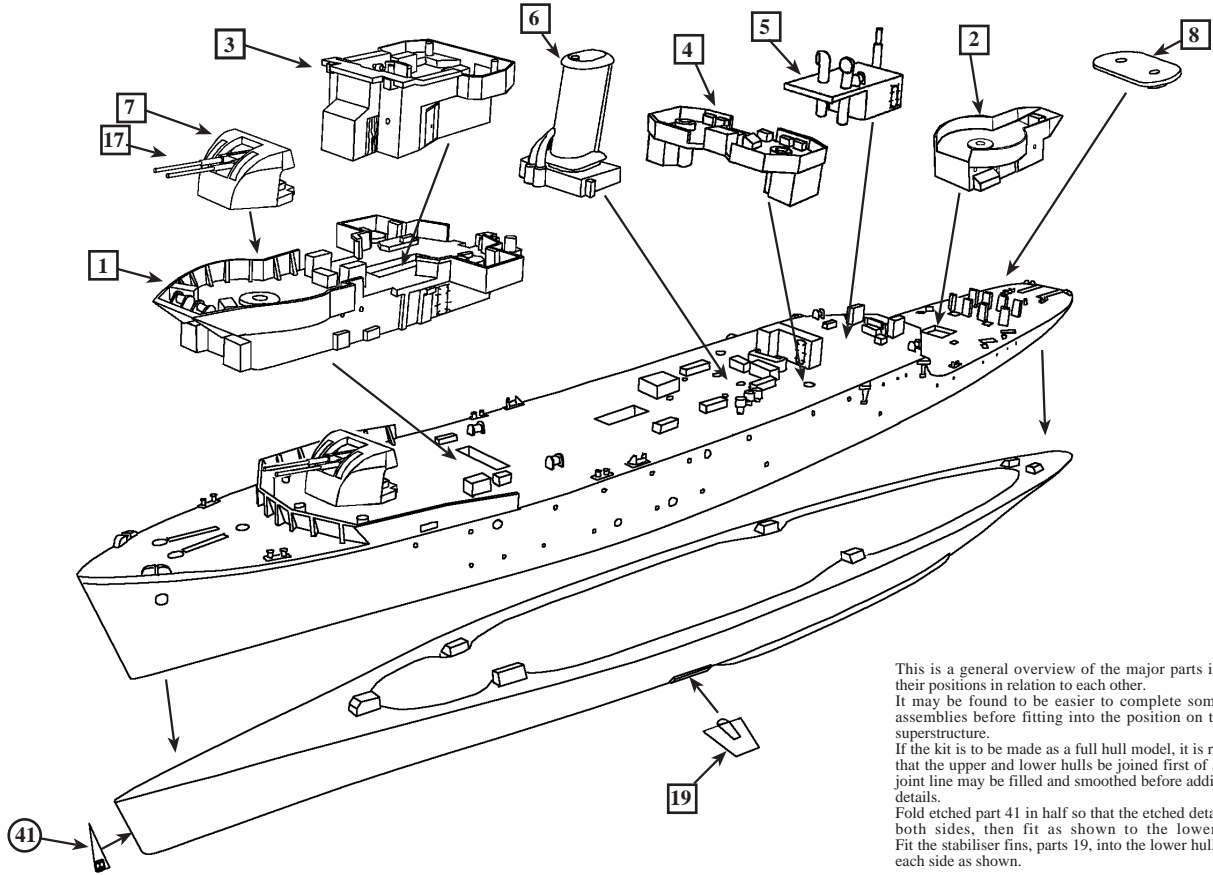

This is a general overview of the major parts in the kit and their positions in relation to each other.

It may be found to be easier to complete some of the sub assemblies before fitting into the position on to the hull or superstructure.

If the kit is to be made as a full hull model, it is recommended that the upper and lower hulls be joined first of all. Then any joint line may be filled and smoothed before adding any of the details.

Fold etched part 41 in half so that the etched details appear on both sides, then fit as shown to the lower hull stem. Fit the stabiliser fins, parts 19, into the lower hull positions on each side as shown.

Anchor Assembly

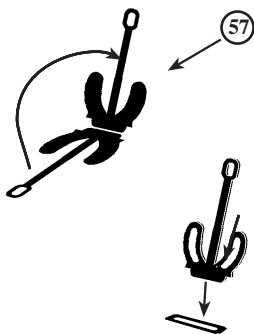

Assemble photo etched anchors 57 as shown above, by fitting the fluke base into the slot in the tipper palm.
Fit anchors into the hawse pipes each side of the bow, after first drilling out the holes with a 1.5mm drill bit.

20mm Oerlikon

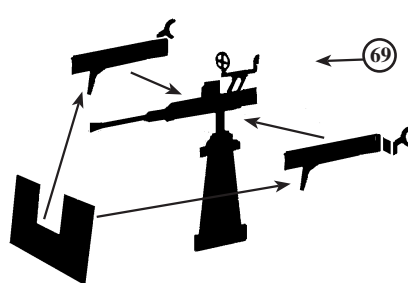

Assemble the single 20mm Oerlikons, etched parts 69, by first twisting the shoulder braces round to 90° then bending the arms back so that they are parallel. Fit the side plates to the centre of the gun body as shown above.
Fit the shield into position centrally on the spigots below the barrel.
These gun mountings are located on the platforms on each side of the bridge superstructure below the signal platforms.

285 Yagi Antenna

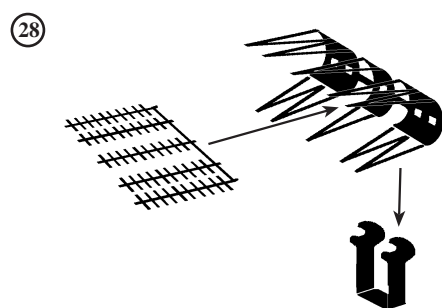

Assemble the 285 Fire Control antenna by folding a gentle curve on to the rectangular reflectors then folding over the stays so that they face forwards.
Fit the set of dipoles centrally on to the reflector faces, locating the pegs into the slots.
Nip the pointed ends of the stays together so that they trap the centre bar of the dipoles between them. Fit the mounting arms to the spindles between the reflectors.
The complete assembly then fit on to the top of the main gun director part 31, so that the points face over the front of the director.

Fo'c'sle Fittings

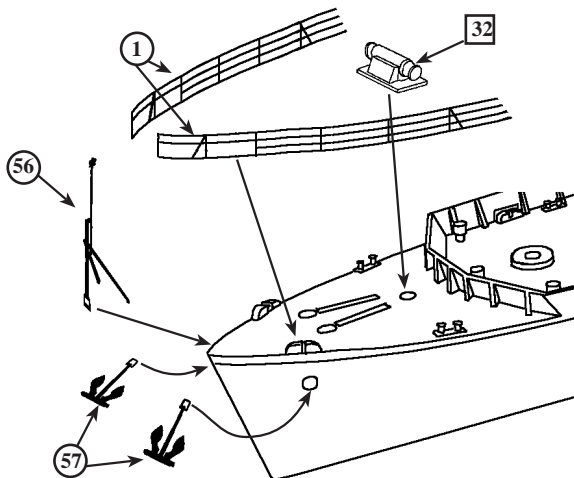

Fit the etched parts on to the fo'c'sle area as shown. Etched anchor chain, part 20, has been provided to fit between the hawse pipe holes and the Windlass, part 32.

Forward Superstructure

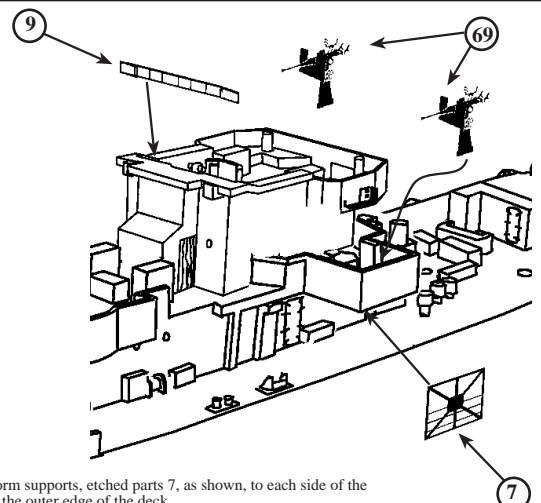

Fit the gun platform supports, etched parts 7, as shown, to each side of the superstructure at the outer edge of the deck.
Shape and fit the bridge windshield, etched part 9.

HACs Mk3 Director Assembly

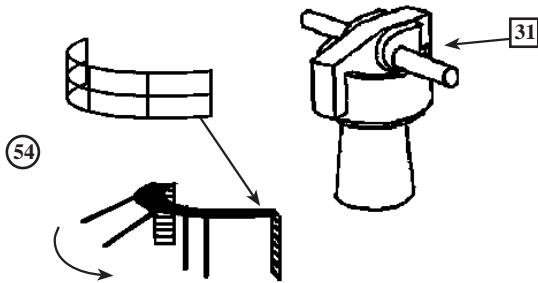

Fold the support legs and vertical ladders to 90° on the HACs Director catwalk, etched part 54. Curve and fit the safety rail as shown. Note. This catwalk does not fit directly on to the director, but sits on the bridge deck by its support frame, just in front of the director.

Bridge and Director Fittings

Assemble the Mk 3 Director, part 31, to the bridge deck. Then locate and secure the catwalk assembly 54, centrally and just in front of the director. Fit the 285 yagi assembly, 28, to the top of the director as shown.

Fold the legs of the HF/DF antenna, 60, back to the position shown right. Fit the antenna in front of the wireless house as shown.

Fit the binocular sights, 70, to the pedestal mounts on each side of the signal platform. These binocular sights are folded in half so that they are double thickness with the fold making the attachment foot.

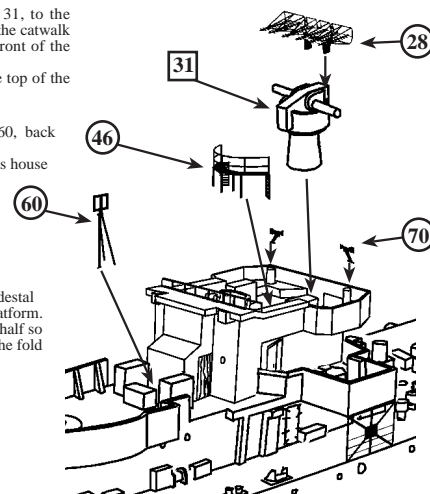

Bridge Canopy

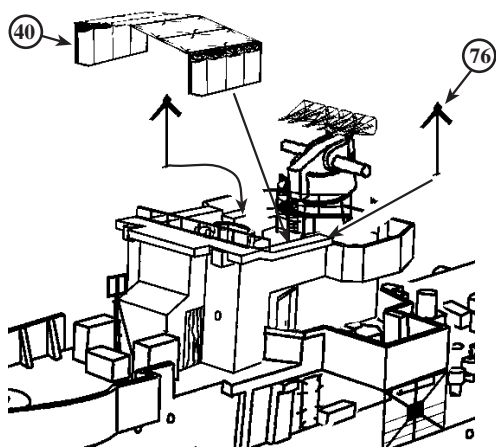

If it is desired to fit the bridge canopy, fold down the side supports of etched part 40. Fold along the centre line so that the roof has a slight run off on each side as shown above. Locate the support frame to the tops of the bridge bulwarks. For the early version of the ship, fit the semaphores, etched parts 76, against the rear uprights of the canopy frame.

Fore Mast Assembly (Early Fit)

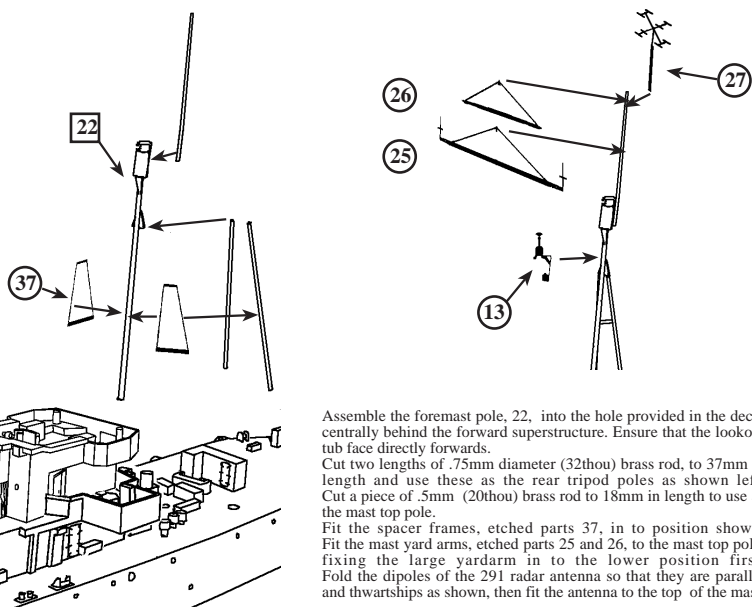

Assemble the foremast pole, 22, into the hole provided in the deck, centrally behind the forward superstructure. Ensure that the lookout tub face directly forwards. Cut two lengths of .75mm diameter (32thou) brass rod, to 37mm in length and use these as the rear tripod poles as shown left. Cut a piece of .5mm (20thou) brass rod to 18mm in length to use as the mast top pole. Fit the spacer frames, etched parts 37, in to position shown. Fit the mast yard arms, etched parts 25 and 26, to the mast top pole, fixing the large yardarm in to the lower position first. Fold the dipoles of the 291 radar antenna so that they are parallel and thwartships as shown, then fit the antenna to the top of the mast.

Fore Mast Assembly (Late 1944 Onwards)

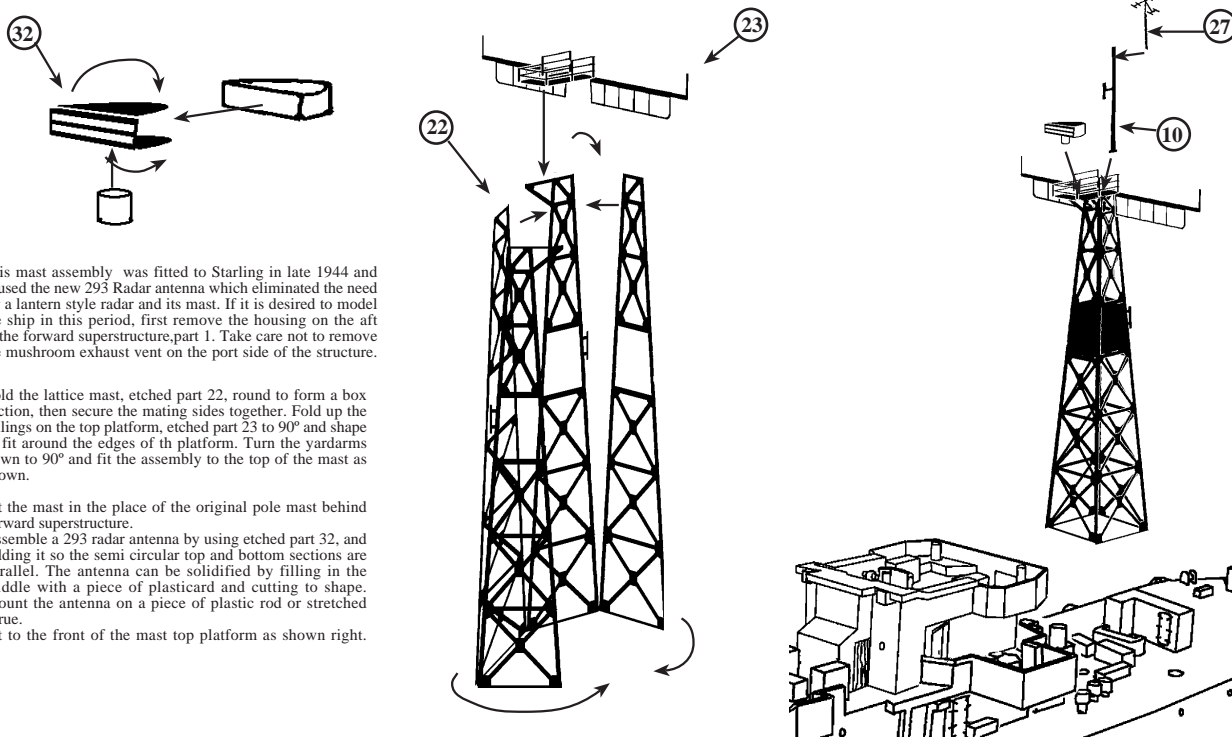

This mast assembly was fitted to Starling in late 1944 and housed the new 293 Radar antenna which eliminated the need for a lantern style radar and its mast. If it is desired to model the ship in this period, first remove the housing on the aft of the forward superstructure, part 1. Take care not to remove the mushroom exhaust vent on the port side of the structure.

Fold the lattice mast, etched part 22, round to form a box section, then secure the mating sides together. Fold up the railings on the top platform, etched part 23 to 90° and shape to fit around the edges of the platform. Turn the yardarms down to 90° and fit the assembly to the top of the mast as shown.

Fit the mast in the place of the original pole mast behind forward superstructure.

Assemble a 293 radar antenna by using etched part 32, and folding it so the semi circular top and bottom sections are parallel. The antenna can be solidified by filling in the middle with a piece of plasticard and cutting to shape. Mount the antenna on a piece of plastic rod or stretched sprue.

Fit to the front of the mast top platform as shown right.

Funnel Assembly

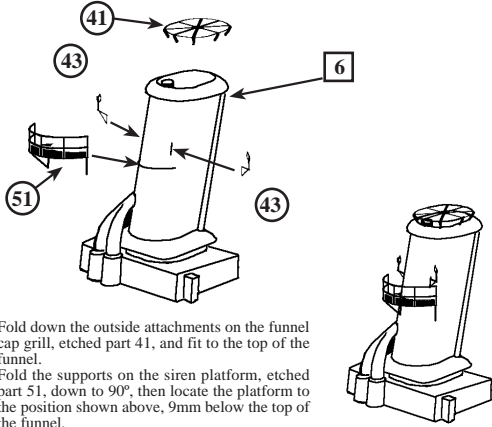

Fold down the outside attachments on the funnel cap grill, etched part 41, and fit to the top of the funnel.
 Fold the supports on the siren platform, etched part 51, down to 90°, then locate the platform to the position shown above, 9mm below the top of the funnel.
 Fit the sirens, parts 43, to each side. Locate the funnel assembly to the main deck just forward of the amidships AA platform.

40mm Bofors (Hazemeyer)

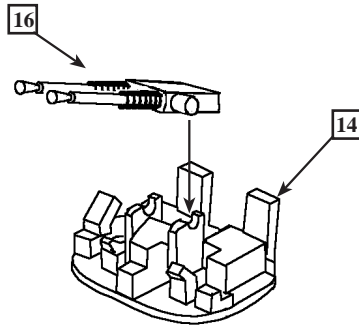

If the Starling is to be modelled from the late 1944 fit. The two amidships 20mm mounts were replaced by two twin 40mm Bofors as provided for here.
 Assemble parts 14 and 16 into the desired positions.

Hazemeyer Yagi Assembly

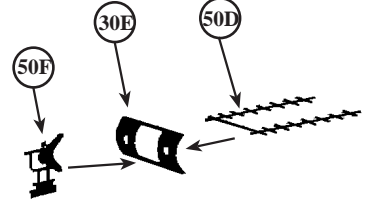

Assemble the yagi radar antennas by curving the rectangular dishes of etched parts 30E as shown. Fit the dipoles in to the holes in the centre of the dishes do that they are parallel.
 Fold part 30F in half so that the etched detail is outermost, then attach centrally to the two joining bars between the radar dishes.

40mm Bofors (Hazemeyer) Assembly or 20mm Early Fit

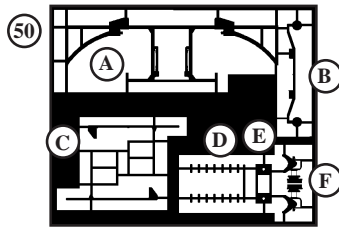
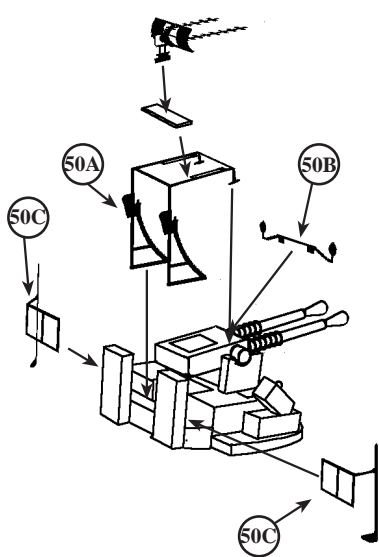

Fold the central mounting frame, part 50A, so that the sides are parallel.
 Fit the frame so that the main legs fit behind the gun barrels and the small forward feet fit on top of the gun body.
 Fit a small strip of thin (10thou) plasticard across the top of the frame on which to mount the yagi antenna as shown left.
 Fit the rear railings and gunsights to the positions shown.

Fit the 40mm Bofors to the amidships AA platform as shown right, or, if the early fit is being modelled fit the two twin 20mm power mounts, parts 15.

Note. The 40mm Bofors were only fitted to Starling after the later lattice mast was fitted.

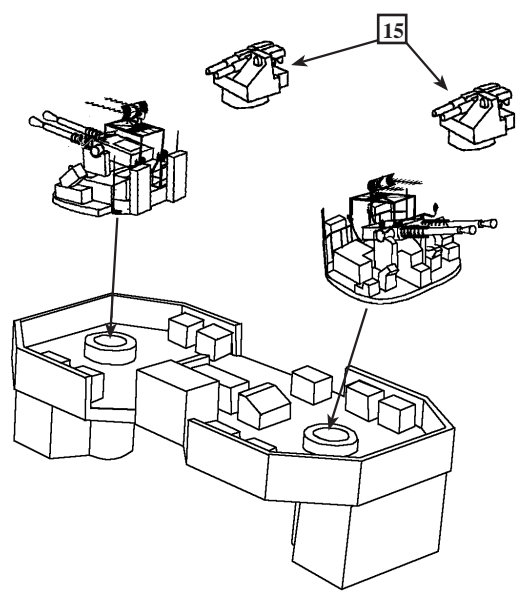

4" HA/LA Gun Mounting

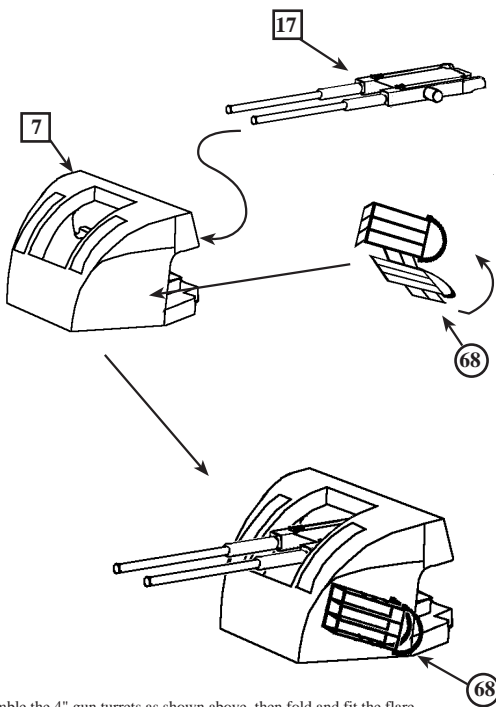

Assemble the 4" gun turrets as shown above, then fold and fit the flare rocket launcher, etched parts 68, to each side of 'B' turret only.

Radar Lantern Mast (Late 43)

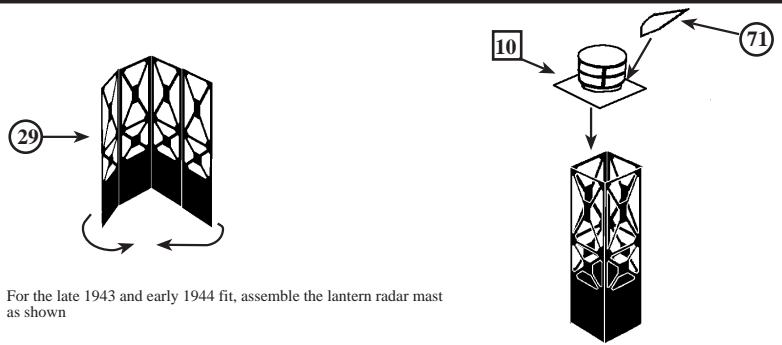

For the late 1943 and early 1944 fit, assemble the lantern radar mast as shown

Searchlight Fitting

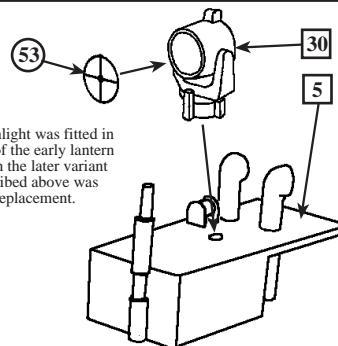

The searchlight was fitted in the place of the early lantern radar when the later variant mast described above was used as a replacement.

Aft Ladder Assembly

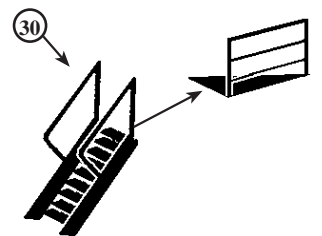

Assemble the two quarter deck step ladders as shown above.
 The steps may be angled so that they are flat, by using a pair of needle point tweezers.
 Ensure that the angled landings are made as mirror images of each other, so that they fit to port and starboard sides of the step.

Deck Step Area Fittings

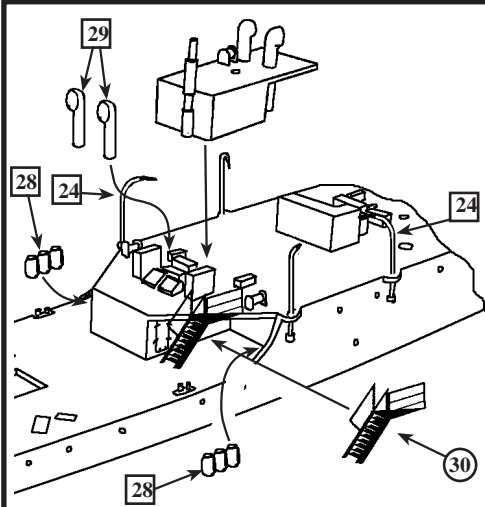

Fit the cowl vents, parts 29, into the holes in the deck that are located between the ammunition lockers. Fit the smoke generator canisters, 28 to the deck inside the sloped fairing.
Fit the aft boat davits, parts 24, to the protruding fixings as shown.

Radar Lantern Variants

If the early version of the lantern radar, part 9, is to be used, fit directly to the top of the deck house and delete the searchlight part.
Make a pole type main mast wire antenna spreader from a piece of .5mm brass rod, cut to a length of 25mm. A recess may be drilled into the deck, centrally behind the ammunition lockers, to assist with location.

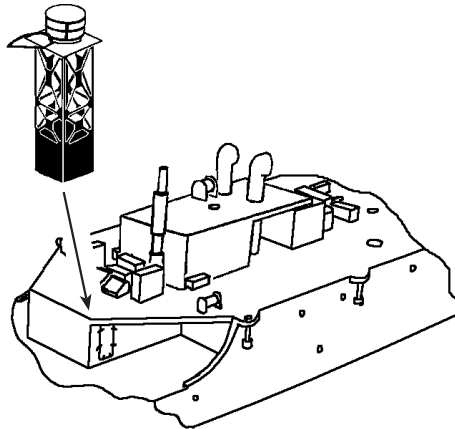

If the late type of lantern radar is to be used, fit the assembly shown left centrally to the deck behind the ammunition lockers as shown.
The searchlight assembly is now located on top of the deck house behind the cowl vents.

Aft 20mm Mounting Platform

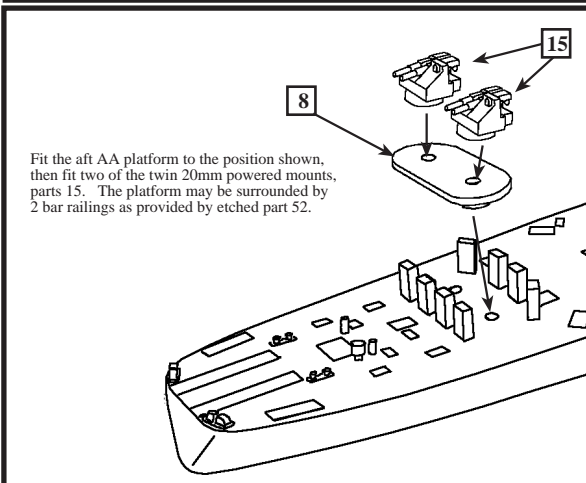

Fit the aft AA platform to the position shown, then fit two of the twin 20mm powered mounts, parts 15. The platform may be surrounded by 2 bar railings as provided by etched part 52.

Ships Boats Assembly

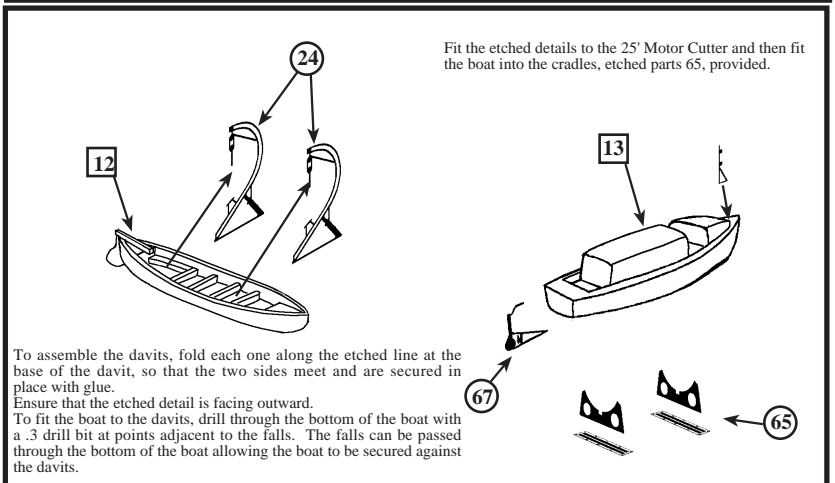

Fit the etched details to the 25' Motor Cutter and then fit the boat into the cradles, etched parts 65, provided.

To assemble the davits, fold each one along the etched line at the base of the davit, so that the two sides meet and are secured in place with glue.
Ensure that the etched detail is facing outward.
To fit the boat to the davits, drill through the bottom of the boat with a .3 drill bit at points adjacent to the falls. The falls can be passed through the bottom of the boat allowing the boat to be secured against the davits.

Ships Boats Location (Starboard)

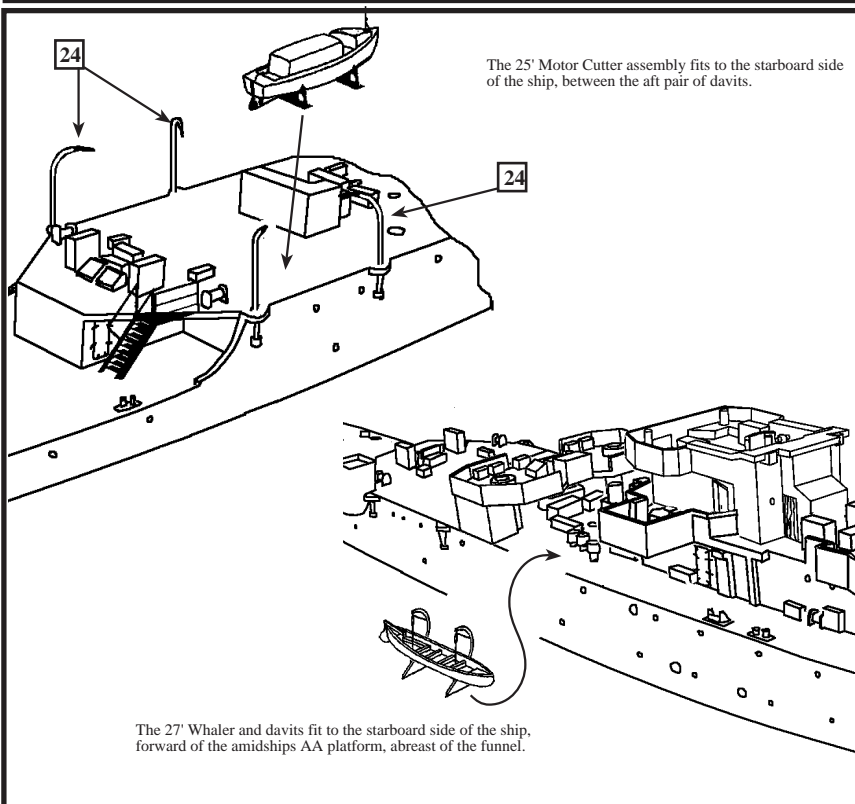

The 25' Motor Cutter assembly fits to the starboard side of the ship, between the aft pair of davits.

The 27' Whaler and davits fit to the starboard side of the ship, forward of the amidships AA platform, abreast of the funnel.

Ships Boats Location (Port)

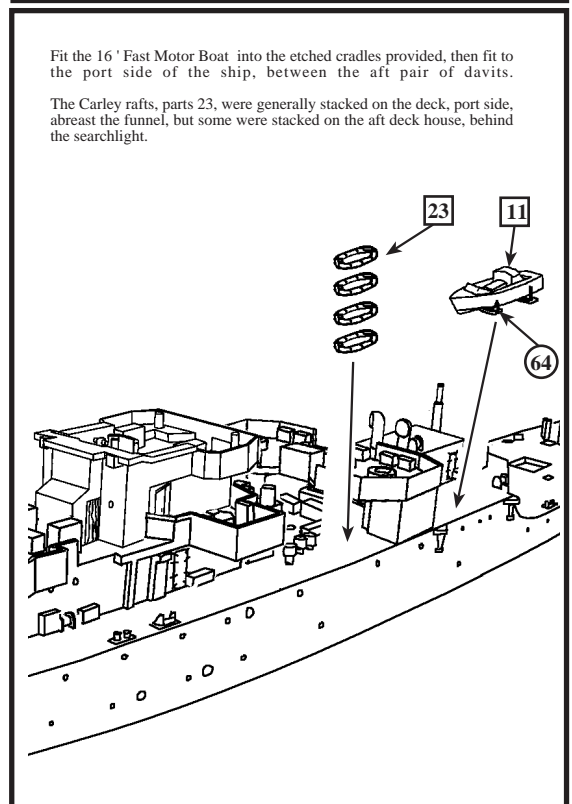

Fit the 16' Fast Motor Boat into the etched cradles provided, then fit to the port side of the ship, between the aft pair of davits.

The Carley rafts, parts 23, were generally stacked on the deck, port side, abreast of the funnel, but some were stacked on the aft deck house, behind the searchlight.

Depth Charge Delivery Systems Assembly

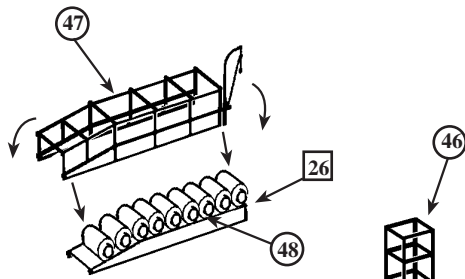

Assemble the depth charge rails by folding the sides of etched parts 47 down so that they are parallel. Then fit the depth charges onto the chute, etched part 48, in between as shown above. Repeat on second assembly. Fit the depth charge rails on to the raised guides on the stern, as shown far right. Ensure that the handling davits are on the outboard sides.

Fold the frames of etched parts 46 around, to make a box section as shown, then fit a stack of three depth inside the frame. Make four of these. These were the ready use depth charges for the side throwers.

Fit the depth charge throwers, parts 25, on to the raised guides on the deck as shown. Fit a depth charge stack assembly forward of each depth thrower. Fit a handling davit, etched part 63, inboard of each of the depth charge stack assemblies.

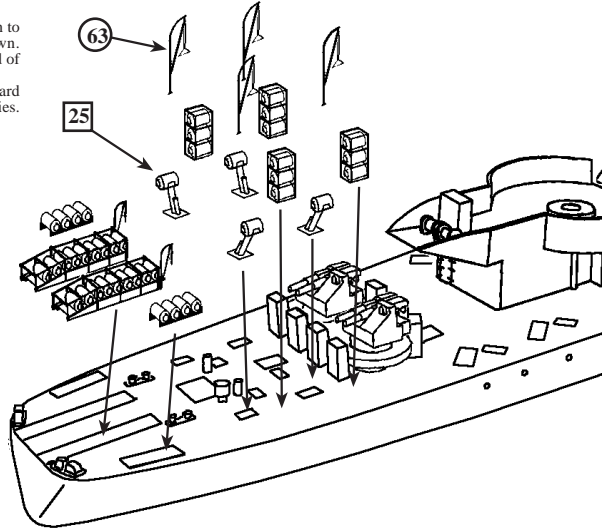

Additional Depth Charge Stowage Racks and Locations

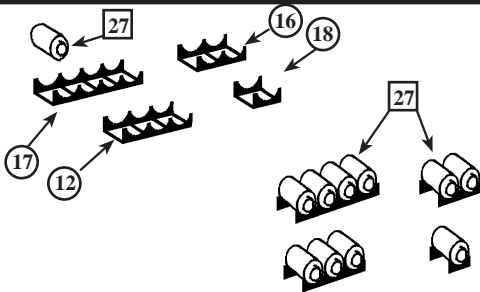

Deck stowed depth charges were placed in cradles containing varying numbers of charges. Cradles for single and up to four depth charges have been provided for in etched parts 48 and 50. Fold up the side of the cradles to 90° so that they are parallel. Cut the required number of depth charges from the strips of four provided, parts 27, and fit into the cradles.

Use the diagram on the right for the placement of these stowage cradles on the deck, in relation to other fixtures and fittings.

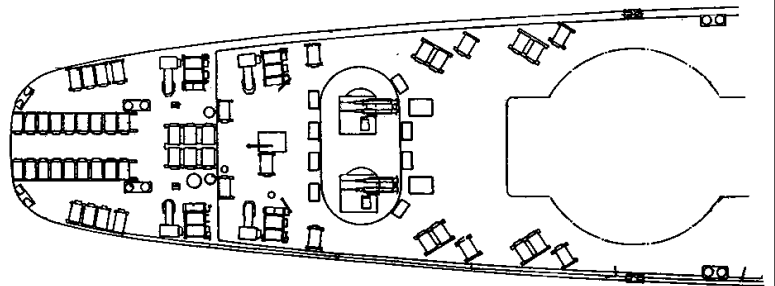

Main Deck and Quarterdeck Railing Location

Fit the six sections of railings, etched parts 2, to each side of the main deck edges, so that they fit between the AA gun platform supports, as shown. The after most section is shaped around the edge of the deck step and may need the small extension pieces to take the railing up to the inclined ladders.

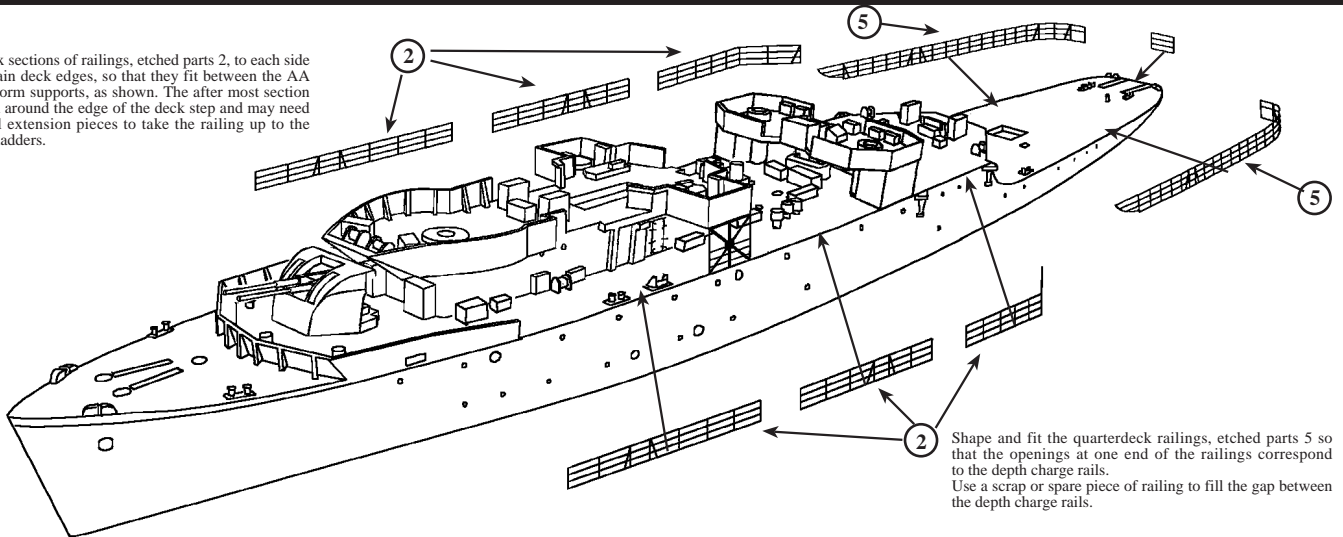

Shape and fit the quarterdeck railings, etched parts 5 so that the openings at one end of the railings correspond to the depth charge rails. Use a scrap or spare piece of railing to fill the gap between the depth charge rails.

'B' Gun Deck Railing Location

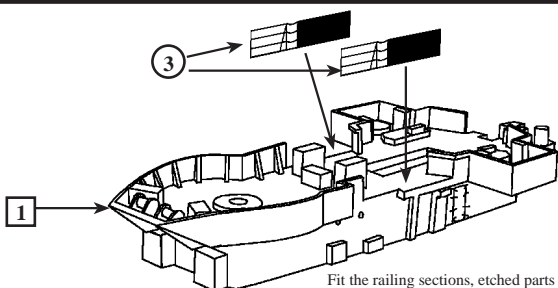

Fit the railing sections, etched parts 3, to the sides of 'B' gun deck. Vertical ladder, etched part 21, may be cut to length and fitted to the sides of the superstructure below the narrow gap in the railing stanchions.

Searchlight Platform Railings

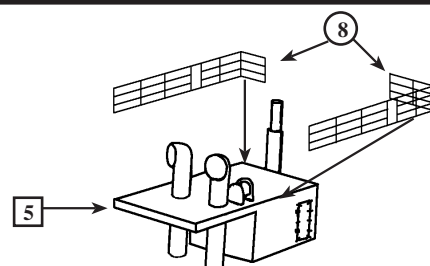

Fit the railing sections, etched parts 8, to the sides of the searchlight platform. Vertical ladder, etched part 21, may be cut to length and fitted to the sides of the deck house below the narrow gap in the railing stanchions.

Propeller and Rudder Assembly

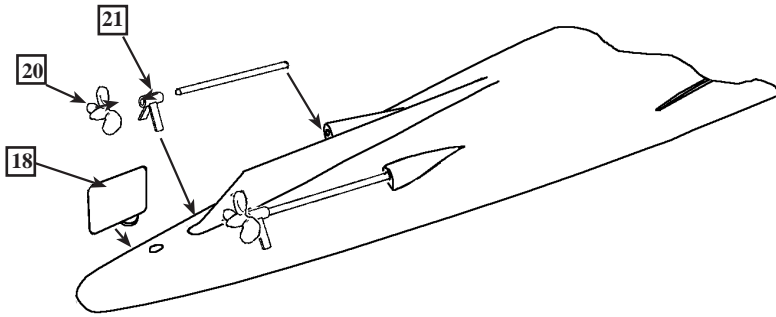

If the ship is to be modelled full hull, the running gear will be required. Fit the propellers to the 'A' frames as shown, then cut two pieces of .75mm (32thou) brass rod to the length of 15mm to use as shafts. Assemble the shafts and propellers as shown above. The legs of the 'A' frames may be over length to allow that they may be trimmed to achieve the correct position. Fit the rudder, part 18, into the central locating hole.

20mm Twin Oerlikon Mountings Photo Etch Parts

Fold up the barrels on the 20mm twin, etched parts 46, to 90° so that they are parallel on the rectangular base plate. Fit the guns to the flat area on the side of the powered gun mountings as shown above. Make four of these

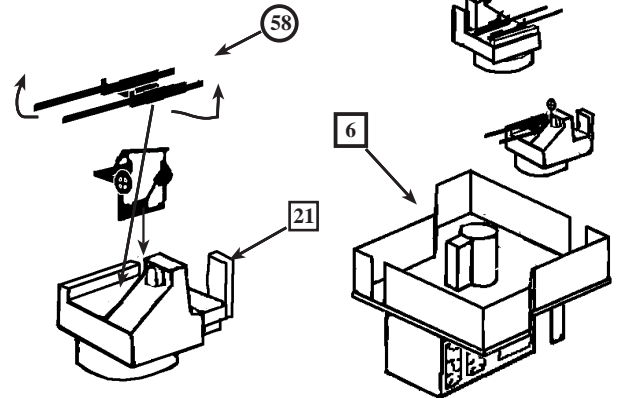

Remove any flash or molded bulwarks from the edges of the 20mm Oerlikon platform, resin part 6. Fit the platform to the ship's hull so that the locating pegs and holes on the deck align. Fit the assembled 20mm power mountings as shown above.

Other Instructions

1. Cowl vent grills, etched parts 75, are provided to fit over the cowl vent openings if desired.
2. Signal lamps, etched parts 52, are provided to fit on to the bulwarks of the signal platforms on either side of the bridge.
3. Sufficient name plates, etched parts 11, have been provided to enable the modeller to build any of the war survivors of the Black Swan class. These are fitted on each side of the aft superstructure section below the aft 4" gun mounting.
4. The ensign staff, etched part 66, come with the aft boat boom fitted as an integral part. The boom may be removed with a sharp knife if desired, so that the ensign staff may be fitted clean, on the stern, between the depth charge rails.
5. Anchor chain, etched parts 20, has been supplied in sufficient lengths to enable the modeller to portray the ship at anchor in a diorama setting. These lengths can be run from the windlass on the focsle, through the hawse pipe holes, down to the surface of the water scape..
6. The photo etched set provided in this kit, is a universal set that covers the Black Swan class ships from their WW2 days through to their final appearance. There is also an extra lattice main mast provided, etched parts 61 and 62, to assist any modeller wishing to build HMS Starling or Redpole when they fitted as training ships during the 1950s

Painting Guide and Colour Chart

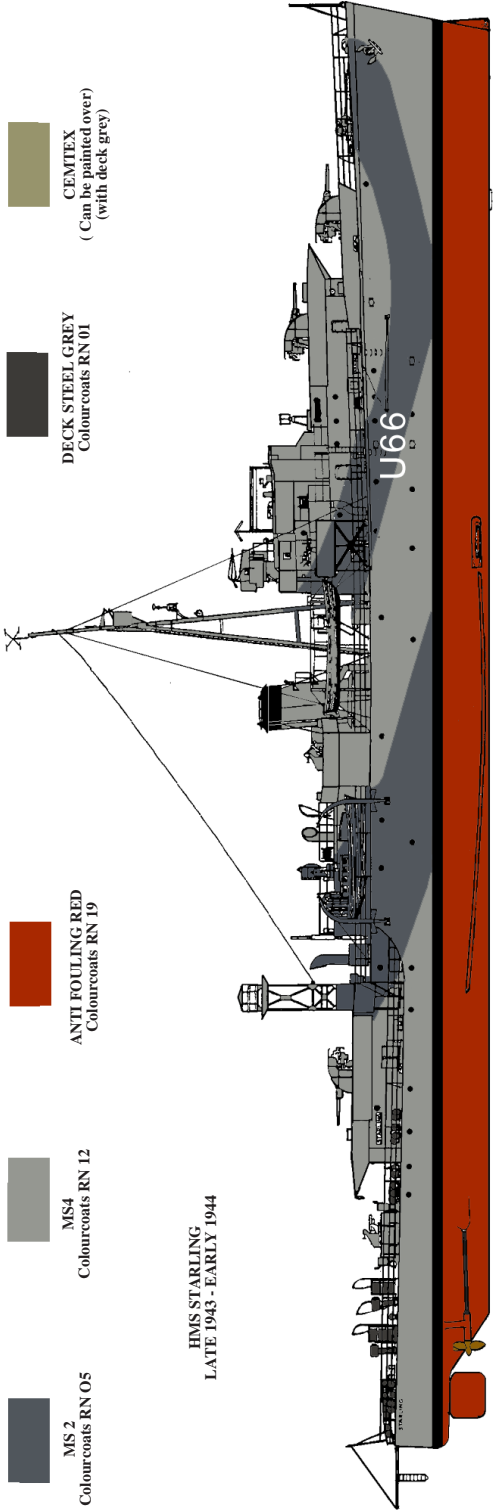

MS 2
Colourcoats RN 05

MS4
Colourcoats RN 12

ANTI FOULING RED
Colourcoats RN 19

HMS STARLING
LATE 1943 - EARLY 1944

DECK STEEL GREY
Colourcoats RN 01

CEMTEX
(Can be painted over)
(with deck grey)

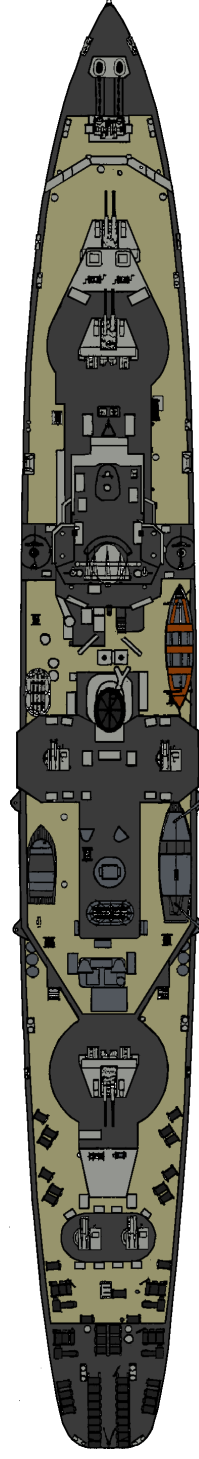

AP 507C
Colourcoats RN 03

ANTI FOULING RED
Colourcoats RN 19

Other Colours Used:-

Matt Black..... Funnel Cap and Top Band
Waterline Boot Topping, AA
Gun Barrels.

Teak Whaler Thwarts
Bronze Propellers

HMS STARLING
LATE 1944 - 1948

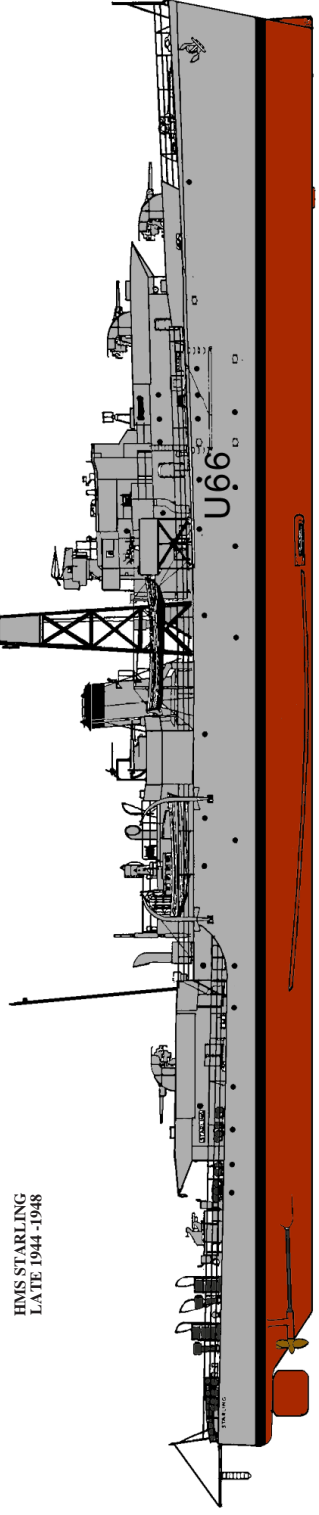

ATLANTIC MODELS © 2016

1 Hillview Grove, Easington, Durham, SR8 3NT. UK Tel. 0191 5271574
e.mail: peter@atlanticmodels.net Website http://www.atlanticmodels.net