

**Landing Craft (LCU) Details**

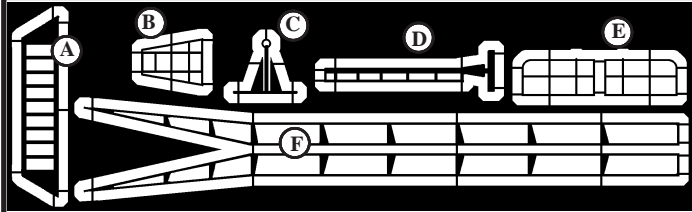

A small fret of parts has been provided to finish off the Landing Craft LCU's with some fine details. If any vehicles or tanks are needed to make up a diorama, it is recommended that Starling Models website is visited <https://starling-models.co.uk> where a range of armoured and soft skin vehicles can be found in 1/350 scale.

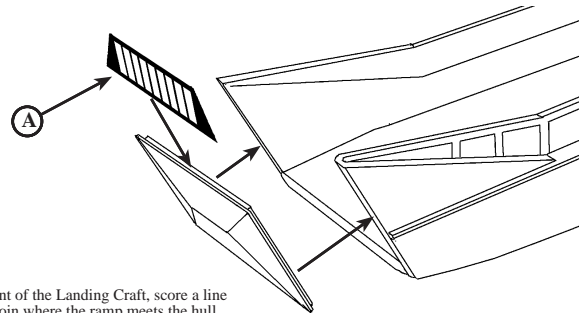

To close the ramp at the front of the Landing Craft, score a line along the under side at the join where the ramp meets the hull. When the line is deep enough the ramp will snap off cleanly and can then be fixed in the closed position.

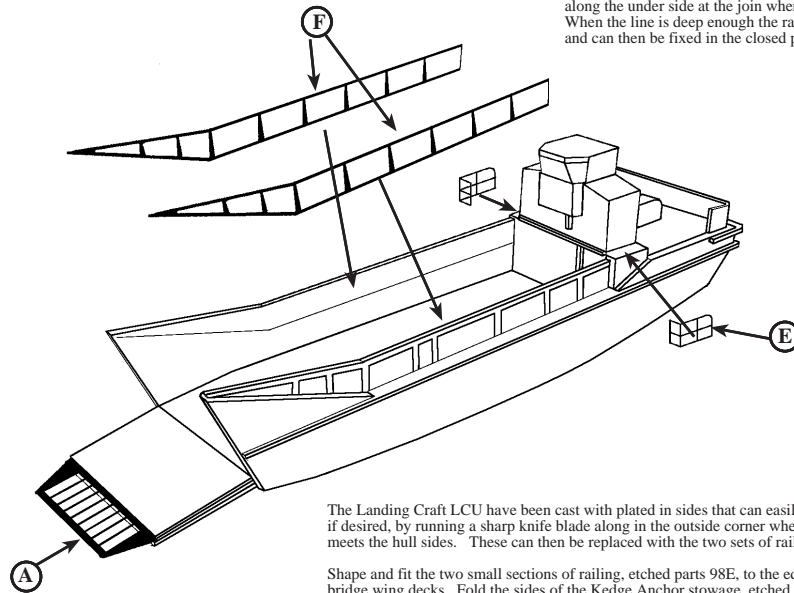

The Landing Craft LCU have been cast with plated in sides that can easily be removed if desired, by running a sharp knife blade along in the outside corner where the plating meets the hull sides. These can then be replaced with the two sets of railings 98F.

Shape and fit the two small sections of railing, etched parts 98E, to the edges of the bridge wing decks. Fold the sides of the Kedge Anchor stowage, etched part 98B, to 90° so that they are parallel, then fit centrally into place on the stern. Fit the Kedge Anchor, 98C, to the frame as shown right.

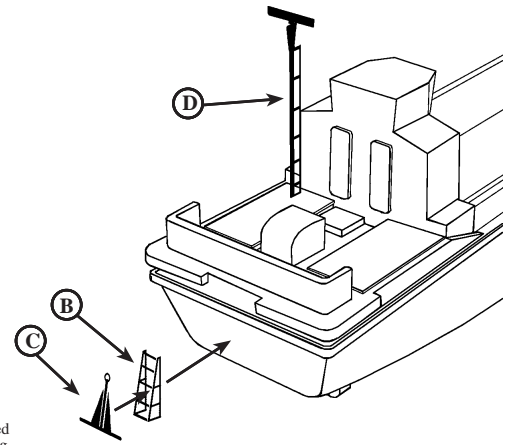

**R.N. Light  
 Weatherwork  
 Grey  
 Humbrol 127**



**R.N. Light  
 Deck Grey  
 Humbrol 106**



**Dirty Wood Planking  
 Dark Earth + Dark Grey  
 Humbrol 29 + 67**



**Anti Fouling Red  
 Humbrol 100**

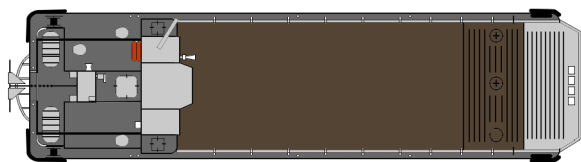
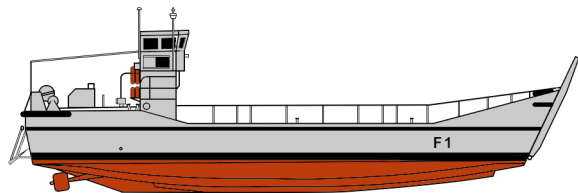

**WARNING**

This kit contains a mixture of resin and photo etched metal parts, of which some of the resin parts have been attached to sprues for ease of casting. Care must be taken when detaching the parts from the sprues, to remove the flash without causing damage. When cleaning off the excess material using files or abrasive paper, it is recommended that a mask is worn as resin dust can be harmful to health if inhaled.