

Parts List

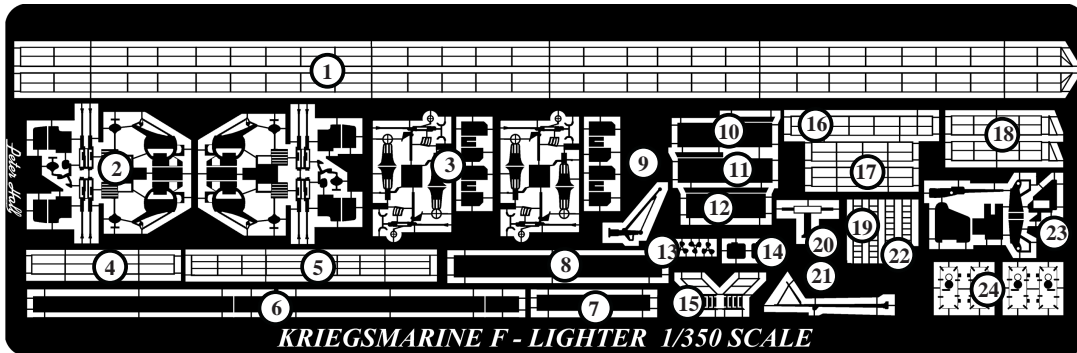

- | | | | |
|----------------------------------|---|----------------------------------|------------------------------|
| 1. Main Deck Safety Railing | 7. Aft Gun Deck Rear Bulwark | 13. Propellers | 19. Aft Vertical Ladders |
| 2. 2cm C38 Flakveirling Assembly | 8. 3.7cm Mounting Splinter Shield | 14. Rudders | 20. Rangefinder Arms |
| 3. 2cm Single Mounting | 9. Forward Crane | 15. Inclined Ladders | 21. Mast |
| 4. Stern Railing | 10. Bridge Splinter Shield (Starboard Side) | 16. 2cm Single Deck Rear Railing | 22. Forward Vertical Ladders |
| 5. Bridge Roof Railing | 11. Bridge Splinter Shield (Port Side) | 17. 2cm Single Deck Side Railing | 23. 3.7cm Gun Assembly |
| 6. Aft Gun Deck Side Bulwarks | 12. Bridge Splinter Shield (Front) | 18. 3.7cm Deck Side Railing | 24. Watertight Doors |

3.7cm Single AA Mounting

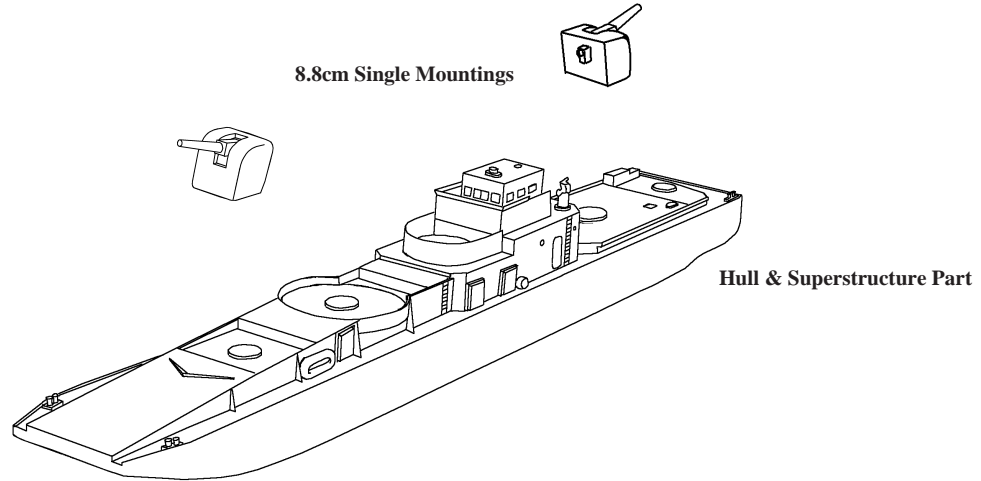
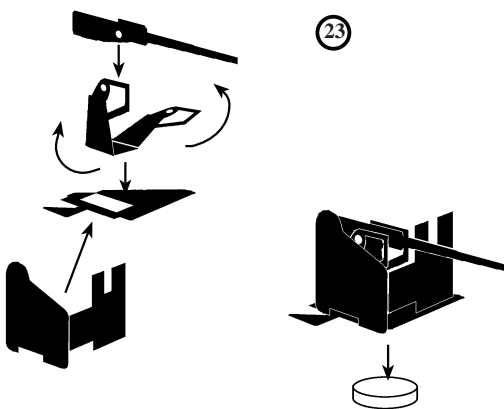

Fold the centre piece of the gun mounting so that the two sides are parallel. Fit on to the base plate as shown.
 Locate the gun barrel between sides of the mounting and secure into position by passing a piece of 10 thou wire or stretched sprue through the holes. The gun barrel can be set at any elevation desired.
 Fold the shield to 90° and fit the recess on the side plate over the extended foot plate. Ensure the barrel passes through the larger of the two slots and not through the sighting slot.
 Fit the completed mounting on to a circle of plasticard before fitting in to position on the model.

2cm Flakveirling C38

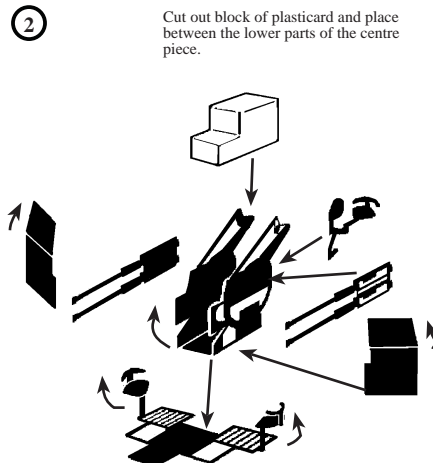

Fold gun layers seats on each side of the base plate to shape as shown above. Fold the centre section of the mounting so that the two sides are parallel. Fit the pairs of barrels to each side, ensuring that they are parallel with each other.
 Fit the shield plates to each side of the mounting as shown.

2cm Single AA Mounting

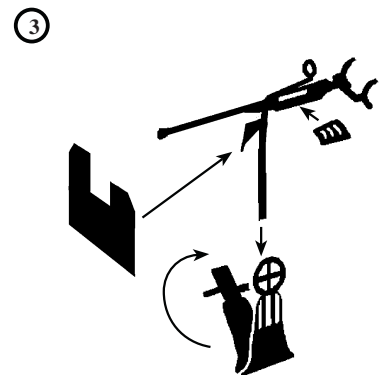

Fold the mounting pintle in half so that etched detail appears on each side, at the same time trapping the extender tube on the underside of the gun in between. Fold the shoulder braces to the shape shown above. Fit the shield centrally to the locating lug below the gun.
 Gun mounting pintles have been moulded in place on the upper deck, and will need to be removed if this mounting is to be fitted complete.
 Alternatively just the etched metal gun barrel and shield may be fitted to the top of the moulded pintle if desired.

Weapon Location Diagram

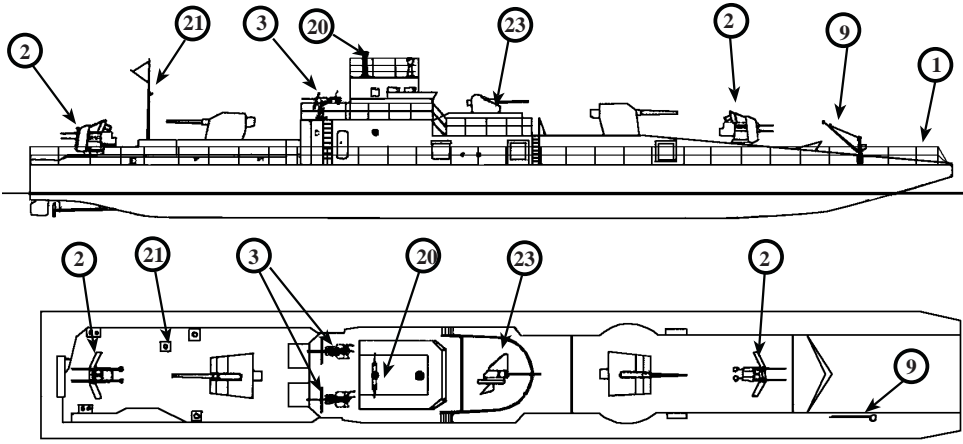

Aft Gun Deck Bulwarks

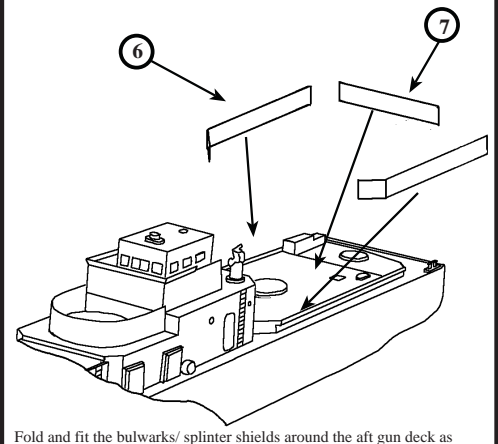

Fold and fit the bulwarks/ splinter shields around the aft gun deck as shown above.

Bridge Area Details

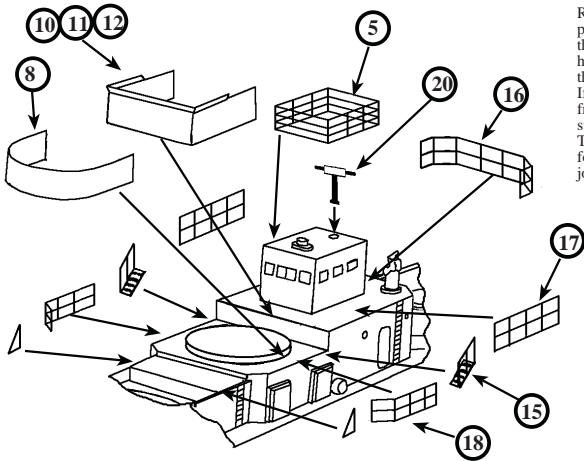

Replacement splinter shields have been provided in photo etched metal, where there is a possibility that the items moulded in place on the superstructure may have been damaged or distorted due to the frailty of those parts.
If the moulded shields are damaged then remove them from the deck with a sharp blade and ensure that the surface is flat before fitting the replacement items.
The bridge splinter shield will need to be assembled by folding the angled lip on the top edge outwards, and joining each of the side sections to the front section.

Propellers and Rudder Fitting

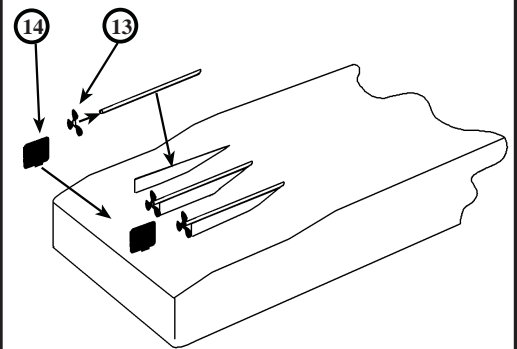

If the model is being built as a full hull display, fit the propellers onto 20thou (.5mm) brass or plastic rod, then fit in place on to the shaft fairings that are moulded to the lower hull.
Fit the two rudders in place so that they are lined up between the inner and outer propellers.

Colour Chart and Painting Guide

STANDARD COLOUR SCHEME

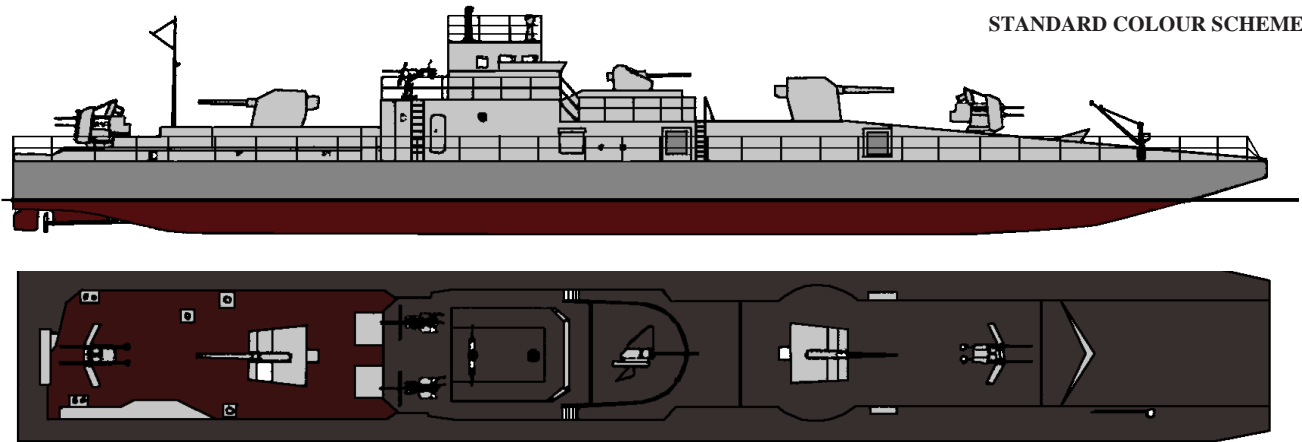

- | | | | | |
|-------------------------------|-----------------------------|--|--|---|
| | | | | |
| Dunkel Grau 51
WEMCC KM 02 | Hell Grau 50
WEMCC KM 01 | Schiffsbodenfarbe III Rot 5
WEMCC KM 04 | Deck Grey Dunkel Grau 2
WEMCC KM 06 | German Camouflage Red Brown
WEMCC ACS 16 |

TYPICAL COASTAL AREA COLOUR SCHEME

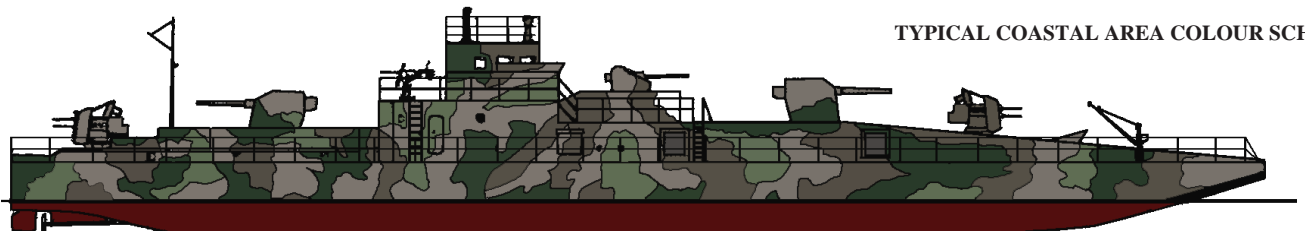

- | | | | | |
|-----------------------------|--------------------------|-------------------------------|-----------------------------|--|
| | | | | |
| Dunkel Grün
WEMCC ARG 05 | Hell Grün
WEMCC RM 05 | Dunkel Braun
WEMCC ACRN 10 | Stein Grau
WEMCC ACUS 05 | Schiffsbodenfarbe III Rot 5
WEMCC KM 04 |

